

Jeremias Model DWKL and SWKL



THE CONICAL JOINT - Intelligent Design

Jeremias, Inc., Marietta, GA

Intelligent Design

Jeremias Model DWKL and SWKL

- Cutaway view of the joints after joining
 - **DWKL** double wall
 - **SWKL** single wall
- Conical joint design, high pressure capable (90" WC), no silicone sealant (steel to steel)
2.2" of surface area at each joint

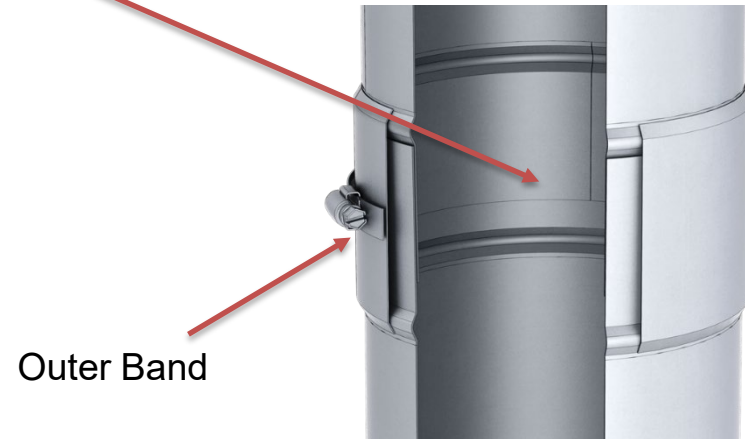
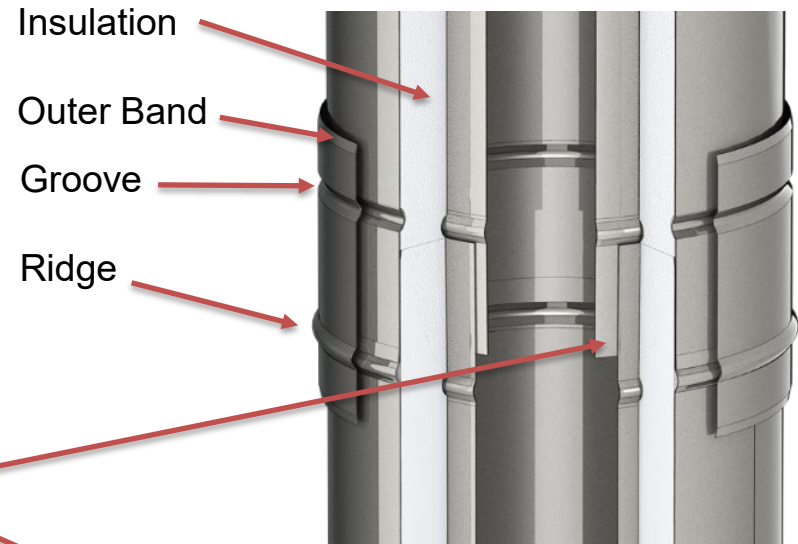

Intelligent Design

Jeremias Model DWKL and SWKL

- Close up view of the joints before joining
 - **DWKL** double wall
 - **SWKL** single wall
- Conical joint design, high pressure capable (90" WC), no silicone sealant (steel to steel)

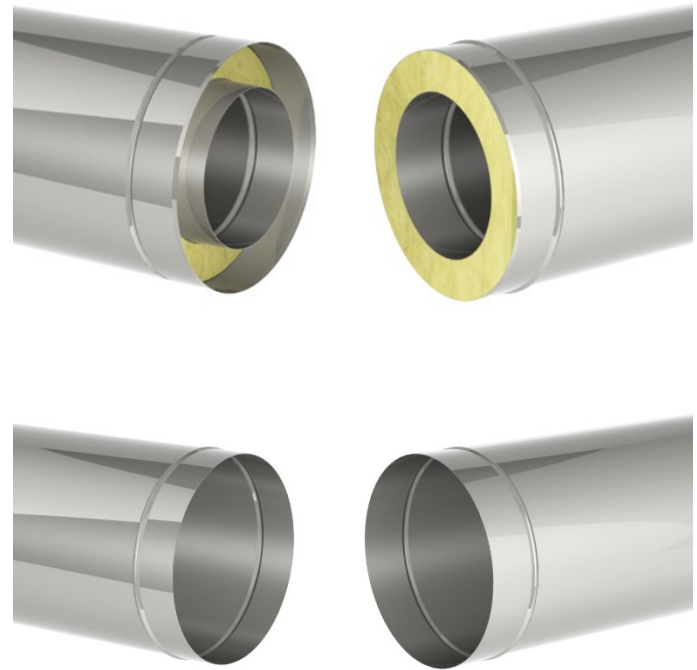

Intelligent Design

Jeremias Model DWKL and SWKL

Assembly of the **DWKL** double wall.

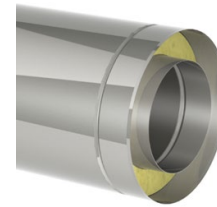

Male end

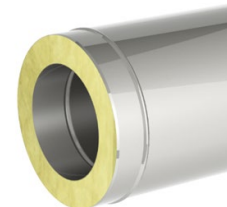

Female end

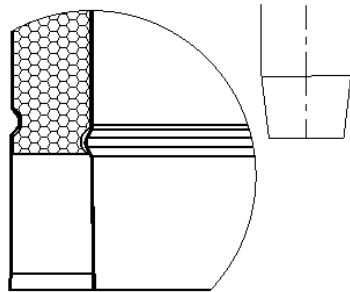

Male end – inner wall

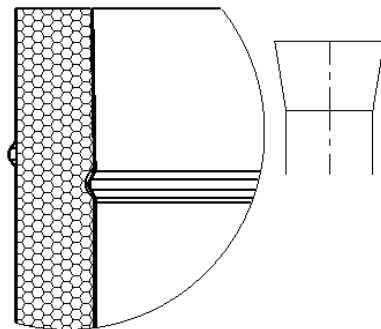

Female end- inner wall

A Closeup Cross-section of the Jeremias Model DWKL shows the male and female ends of the conical joint design prior to assembly.

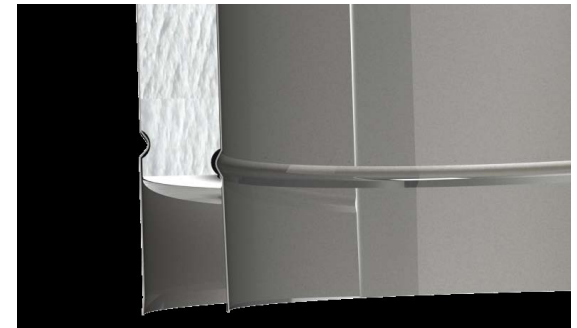

Intelligent Design

Jeremias Model DWKL and SWKL

Assembly of the **DWKL** double wall.

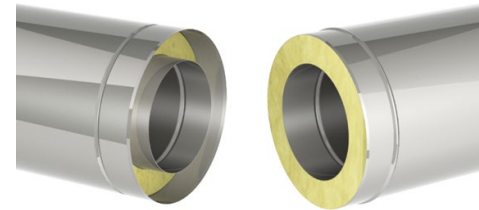

Male end

Female end

A Closeup Cross-section of the Jeremias Model DWKL shows the male and female ends of the conical joint design after assembly.



Competitor- Comparison

Our Competition- Flange to Flange



½" Rolled flanges



Step 1
Fill Inner Vee Band (OVB)
with proper sealant.



Step 2
Position Inner OVB below
flange of pipe or fitting.

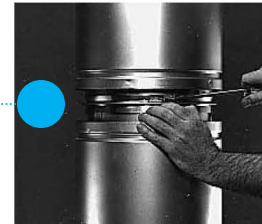

Step 3
Mate flanges of two pipes.
Position Inner OVB over
both flanges and tighten.

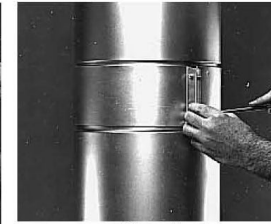

Step 4
Position Outer Channel
Band around outer casing.
Align with pipe grooves and
tighten.

Cut
Fingers?

Competitors vs. Jeremias Comparison

Our Competition- Flange to Flange

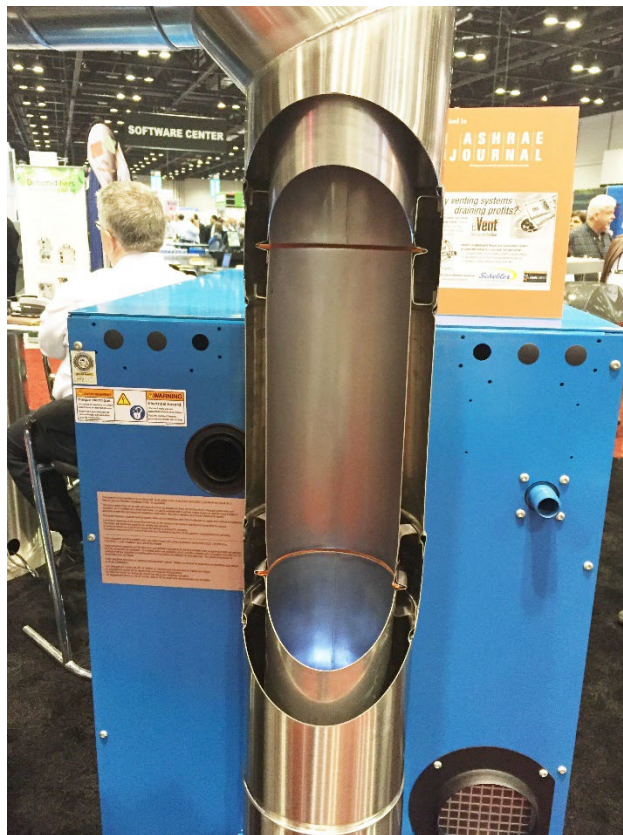

Jeremias- the Conical Joint



Competitors vs. Jeremias

Conclusion

Reasons why Jeremias is better

1. The best response time for quotes, sizings, CAD drawings and calculations- usually same day for quotes
2. The best lead times for shipping- normally 5 to 10 business days standard
3. The best pricing structure in the industry to our reps
4. Truly professional Customer Service- reliable and friendly
5. The ingenious German Conical joint design- No silicon sealant, No gaskets, No leaks
6. Made in the USA
7. All UL Listed
8. The highest UL Listed pressure rating of 90" W.C.- we test stronger
9. The highest UL Listed temperature prior to pressure rating of 1400° F – we test higher
10. The only standard ALL Stainless Steel, including accessories, system on the market- NO rust
11. The only system with no steel bridges between inner liner and outer jacket- less heat transfer- No hot spots
12. The largest steel-to-steel surface area at joint connection- 4 times that of competitor's ½" rolled flanges
13. The smallest footprint in the industry due to best UL clearance to combustibles
14. The best warranty in the industry, 25 year factory warranty
15. The most beautiful finished chimney stack you will ever see
16. Forward thinking company- still inventing and creating, improving every day