

Rectangular Zero Clearance Grease Duct

Model DWGD-RZ

- Rectangular Grease Duct
- Factory Built
- Double-Wall
- Zero Clearance
- Fire Resistive Enclosure

Tested to:

- UL1978/ULCS662
- UL2221/ULCS144
- ULC/S115
- ASTM E814

Installation Instructions

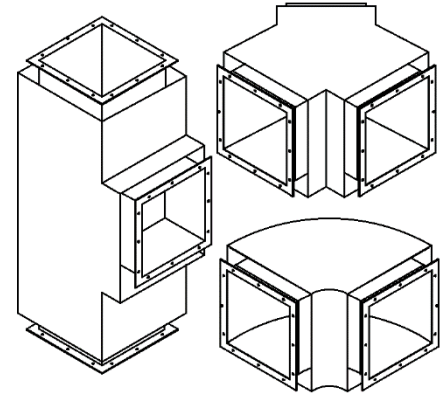
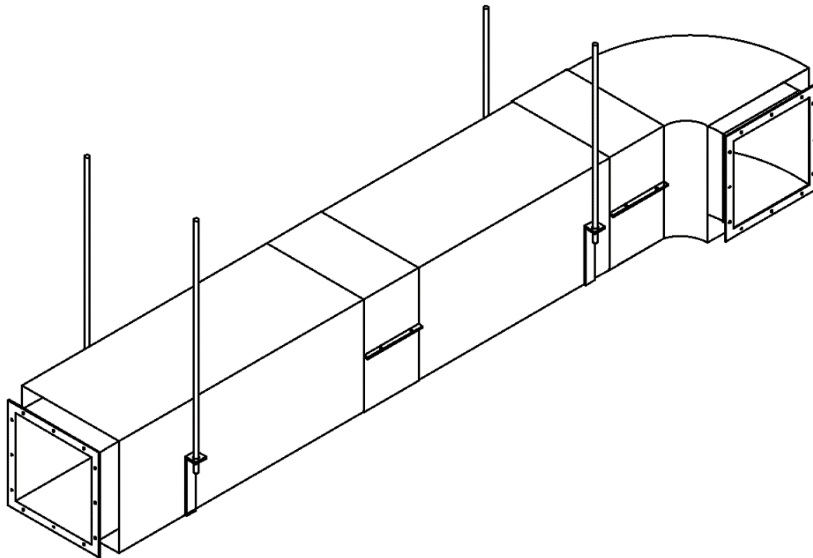

⚠ IMPORTANT

DO NOT INSTALL THESE PRODUCTS UNTIL YOU HAVE READ AND FULLY UNDERSTAND THESE INSTRUCTIONS. FAILURE TO COMPLY WITH THESE INSTRUCTIONS WILL RESULT IN AN IMPROPER INSTALLATION AND WILL VOID THE WARRANTY.

- Examine all components for possible shipping damage prior to installation
- Proper joint assembly is essential for a safe installation – follow these instructions exactly as written and check severeness of joints upon completion of assembly
- This venting system must be free to expand and contract, and must be supported in accordance with these instructions
- Check for unrestricted vent movement through walls, ceilings, and roof penetrations
- Different manufacturers have different joint systems and adhesives – do not mix pipe, fittings, or joining methods from different manufacturers

Keep these instructions for future reference.

For Technical Support or more product information please contact us at 678-388-2740 or visit our website at www.jeremiasinc.com

Pg.	Description	Pg.	Description
3	SECTION 1 – GENERAL INFORMATION	14	SECTION 4 – THIMBLES, PENETRATIONS, FIRESTOP
3	Important Notice	14	Floor Penetration Assembly (FPA)
3	Introduction	15	Wall Penetration Assembly (WPA)
3	Listings / Codes & Authorities	16	Non-Fire Rated Penetrations
3	Installation Considerations	16	Finishing Plate (FPL)
4	Mixing Systems & Parts	16	Flashing (FLS)
4	Duct Size & Slope	16	Counter Flashing (CFL)
4	Cleanouts, Drains & Grease Traps		
4	Wash down & Fire Suppression		
4	Receiving Inspection	17	SECTION 5 – FINISHING, INSPECTION & MAINT.
4	Typical Component Locations	17	Final Check
4	Freight Damage	17	Important Notice
5	Part Identification & Product Code Key	17	Maintenance
5	Suggested Tools, Equipment & Hardware		
5	Safety Notice		
6	Clearances & Additional Enclosures	19	WARRANTY
7	Joint Assembly		
8	SECTION 2 – SUPPORT & GUIDING		
8	Duct Weight		
8	Vertical Support Spacing & Limits		
9	Lateral Guide Spacing		
9	Horizontal Support Spacing		
9	Full Angle Support (FAS)		
9	Guy Attachment Plate (GAP)		
10	Plate Support Assembly (PLS)		
11	Full Support Assembly (FSA)		
11	Wall Brackets (WBR)		
12	SECTION 3 – DUCT SECTIONS & FITTINGS		
12	Duct Sections		
12	Straight Sections (STR)		
12	Elbow (E)		
12	Tee (90T)		
12	Wye Tee (WYE)		
13	Fan/Hood Adapter Assembly (FAA)		
13	Access Panel Section (APS)		
13	Open Top Closure (OTC)		
13	Rain Cap (RCS)		
13	Increasers & Reducers		
13	Single & Double-Wall Adapters		
13	Transition to Round Start & End		

SECTION 1 – GENERAL INFORMATION

IMPORTANT:

These instructions must be followed in all details. Failure to do so may result in a hazardous installation. Contact Jeremias Inc. if there are any questions regarding these instructions.

Introduction

Model DWGD-RZ grease ducts are suitable for the removal of smoke and grease laden vapors from commercial, industrial, institutional, and similar cooking applications where continuous operating temperatures are 500° F (260° C) or less and for intermittent temperatures not exceeding 2000° F (1093° C). Model DWGD-RZ grease ducts are intended to be part of a complete grease duct system which connects the hood or grease extractor with the outdoors by means of an exhaustor or blower system.

Listings

Jeremias Model DWGD-RZ grease ducts are listed by Intertek as a “zero clearance grease duct enclosure assembly” and as “Grease Ducts for Restaurant Cooking Appliances” when installed in accordance with its Intertek listings, these instructions, and the National Fire Protection Association’s standard NFPA 96 “Standard for Ventilation Control and Fire Protection of Commercial Cooking Operations,” International Mechanical Code, Uniform Mechanical Code, or other local codes.

Model DWGD-RZ has been tested in accordance with the procedures and methods set forth by:

- UL 2221 /ULC S144 (Tests for Fire Resistive Grease Duct Enclosure Assemblies/Standard Method of Fire Resistance Test-Grease Duct Assemblies)
- UL 1978/ULC S662 (Standard for Grease Ducts/Standard for Factory-Build Grease Ducts),

Model DWGD-RZ with stainless steel liner is qualified as an alternate to a 2-hour rated fire resistive shaft enclosure; eliminating, in most applications, the requirement for a separate fire resistive enclosure.

Codes & Authorities

Installation must be made in accordance with local and national code requirements. Follow these instructions carefully and contact local building and fire officials about restrictions and installation inspection in your area. Refer to NFPA 96 (Standard for Ventilation Control and Fire Protection of Commercial Cooking Operations) and additional NFPA standards as required.

Installation Considerations

Follow Jeremias’s written installation instructions carefully. Each part of the grease duct system must be installed correctly. Improper or lack of installation of required parts may result in the improper function of the grease duct system.

The grease duct layout should be carefully planned to allow adequate space for assembly, installation of supports, connection of support framing, access for cleanouts, accommodate standard fitting dimensions, rough openings for penetrations, etc. Do not assume all equipment producing smoke or grease laden vapors within a facility can be exhausted with a single grease duct system. Consult a grease duct design professional as required.

One prime coat and finish coat of appropriate heat resistant paint is recommended on exposed installations which are subject to routine cleaning (e.g. kitchen area) and wherever exposed to the weather when the outer shell of components or accessories is constructed from aluminized steel.

Sealing of draw bands, overlapped or butted seams, etc. with an appropriate sealant is recommended on exposed installations which are subject to routine cleaning (e.g. kitchen area) and wherever exposed to the weather in order to avoid moisture from entering the space between the grease duct shell and liner.

Mixing Systems & Parts

Do not connect a grease duct system with any other building ventilation or exhaust system. Do not connect parts from other grease duct manufacturers with Model DWGD-RZ components without the expressed consent of Jeremias.

Components from other Jeremias product lines, (for example Model DWFL), may be mixed with Model DWGD-RZ components to complete a grease duct system as long as: clearances, limitations, codes, etc. are followed. Contact Jeremias for more information concerning product lines which are listed for use as grease ducts.

DWGD-RZ systems are intended to be installed as a complete system without the use of other manufacturer or field fabricated components. However, Jeremias recognizes the occasional requirement for a where systems must be mixed duct due to space constraints at certain locations in a system, or when making modifications or additions to an existing grease duct. In such a case, it is permissible to transition to and from Model DWGD-RZ Grease Duct to a code compliant, rectangular or round, welded steel grease duct and back again. In such a case, Jeremias will manufacture and supply a custom single wall stainless steel transition, meeting code thickness requirements, that permits field welding to or from the field welded duct section(s). Maintain the minimum air space to combustibles of 18" with these custom transitions. Follow NFPA-96 regarding methods for reduced clearances for these single wall custom transitions as well as the field fabricated grease ducts.

Duct Size & Slope

Mechanical codes and good practice require that slope (back to a grease reservoir or kitchen hood) be created to prevent pooling of grease within horizontal portions of grease duct systems. Model DWGD-RZ grease ducts must be installed accordingly to comply with the requirements as described in order to maintain a listed installation. UL 2221 standard (Tests for Fire Resistive Grease Duct Enclosure Assemblies) states that these grease ducts must comply with requirements as set forth by UL 1978 (Standard for Grease Ducts), NFPA 96 (Standard for Ventilation Control and Fire Protection of Commercial Cooking Operations), and the International Mechanical Code. Model DWGD-RZ grease ducts should be installed at a slope not less than 1/8" vertical rise in 12" horizontal run toward the hood or toward a grease reservoir. Where horizontal ducts exceed 75 feet in length, the slope shall be not less than 1/2" vertical rise in 12" horizontal run. Most Model DWGD-RZ components will permit a small amount of slope as the system is being installed. However, some installations may require elbow / transition type pieces to allow for proper orientation of fittings at the vertical risers prior to and after long horizontal runs. It is also acceptable for ducts to have staggered sloped (e.g., uphill to a peak point, then downhill to a valley point), the distance between a valley point and peak point must follow the limitations above and every valley must allow for grease drainage (i.e., a hood or reservoir). Contact Jeremias for additional information.

Slope	
Horizontal Length	Vertical Rise per Horizontal Run
Less than 75'	1/8" per 12" (0.6° slope)
Greater than 75'	1/2" per 12" (2.4° slope)

Cleanouts, Drains, & Grease Traps

Many Model DWGD-RZ sections, accessories, and combinations can be used for cleanout and inspection access of the grease duct system. Access panel sections, 90° tee sections with end caps, and many other combinations of components can serve as cleanout doors or openings as described by NFPA 96. Grease ducts must be provided with adequate cleanout doors or openings to allow for the inspection and cleaning of the entire grease duct system. Refer to NFPA 96 for specific requirements.

Cleanout, drain, and grease trap requirements may change when grease duct systems are equipped with automatic cleaning and / or some types of fire suppression equipment. Refer to NFPA 96 and additional codes / authorities having jurisdiction for specific duct system requirements.

Wash Down & Fire Suppression

Automatic hot water / detergent wash down and fire suppression systems can be integrated into a Model DWGD-RZ grease duct system by using various components which are readily available (or by request sections can be factory fit) with threaded pipe nipples, couplings, etc.

Receiving Inspection

Compare the packing list items and quantities with the contents of the containers to ensure completeness of the shipment. If the shipment is missing components, please contact Jeremias customer service department at (678)388-2740.

Typical Component Locations

Straight sections, fittings, etc. will be positioned and stacked accordingly to fill the shipping container. Sections of smaller dimensions may be slipped into sections of larger dimensions. Bags of fasteners, sealant, etc. may also be located inside the liner of the various pieces.

Freight Damage

Inspect each box as it is unloaded from the carrier for damage which may have occurred during transit. Should there be any damaged components, the delivery receipt must be signed damaged in order for Jeremias to file a claim with the carrier. If the delivery receipt is signed damaged contact Jeremias immediately. If there are damaged parts and the delivery receipt is not signed damaged, Jeremias or the carrier will not be liable, and damaged parts will be replaced at the customer's expense.

Part Identification & Product Codes Key

Each part manufactured by Jeremias is identified with a product code. The product code contains the Model, Vent size, Part ID, and Other information. Part numbers will typically have the letter "DWGD" prefix, followed by the duct size inside dimension (I.D.), then the part description code, next a special option code(s) and last the liner/shell designation. Part description codes are generally three characters and are either alpha or alpha numeric. Qualifier codes are most often used to designate section lengths, tee projection dimensions, and the large I.D. end of increasers. The following are a couple examples of part numbers with their associated description and part number breakdown.

Example: DWGD12X10E45AL-RZ

Refers to a Model DWGD, 12"X10" I.D., 45 Degree elbow constructed with a 304 S.S. liner and an aluminized steel shell

Product Code Key:

Family	Model	HEIGHT x WIDTH	Part ID	Option	Liner Material	Outer Material	Variant
DW	GD	12x10	E	45	A	L	-RZ
DW=Double Wall	GD=Grease Duct		STR = Straight Section		A = 304 SS	A=304 S.S.	-RZ = Rectangular ZeroClearance
SW=Single Wall			APS = Access Panel Section		B = 316 SS	B=316 S.S.	
			DDS = Duct Drain Section	30=30" long	C = 430 SS	C=430 S.S.	
			E = Elbow	45 Degree		L=Alz. Steel	
			90T = 90° Tee				
			45T= 45° Tee				
			WYE = 90° WYE Section				
			C/D = End Cap with Drain				
			CAP = End Cap				
			FAP = Fan Adapter Plate	*x* Plate Size			
			PLS = Plate Support Assembly				
			FAS = Full Angle Support				
			WBR = Wall Bracket				
			FPL = Finishing Plate				
			FPA = Floor Penetration Assy.				
			WPA = Wall Penetration Assy.				
			FLS = Flashing				
			CFL = Counter Flashing				
			GAP = Guy Attachment Plate				

Suggested Tools, Equipment & Hardware

Reciprocating & Keyhole Saws	Drill	Plumb Bob, Level & Tape Measure	#3 Phillips Screw Driver
Metal Snips	Hammer	Caulk Gun	5/16" Nut Driver
Screwdrivers	Safety Glasses & Gloves	Ladder	Roofing Nails
High Temp Sealant	8-penny nails	#8 1-1/2" x 2-1/2" screws	Framing Square
Anti-Seize for all Stainless-Steel fasteners			

Safety Notice

Product has sharp edges. Use extreme caution while working with product. Always wear proper personal protection equipment (gloves, safety glasses, sleeves, etc.) while working with product.

Clearances & Additional Enclosures

The clearance to non-combustible materials is zero inches.

The clearance to combustible materials is zero inches where the DWGD-RZ is insulated and enclosed by their respective shell, cover, or draw band.

Not to be completely enclosed non-ventilated combustible enclosure

WARNING: Code compliant clearances must be followed where any uninsulated components that are in direct contact with the liner and the component penetrates through the insulation and exits past (or through) the duct shell or draw band. Examples of this would be support assemblies, drain pipes, or any other similar items. Do not install these items near combustible material.

When installed in accordance with these instructions and codes, Model DWGD-RZ grease ducts are equivalent to field fabricated two-hour fire rated grease duct enclosure systems. Do not apply wraps or enclosure materials in direct contact with DWGD-RZ in a manner that adds additional weight to the duct.

Follow NFPA-96 regarding methods of reduced clearances & termination requirements for Grease Duct and/or kitchen exhaust duct systems.

Table 1-1 - Clearance to Combustibles – Grease Duct

Minimum Airspace Clearance to Combustibles	
Model:	DWGD-RZ
Application:	Grease Duct & Fire Resistant Enclosure UL1978 & UL2221
Square 6"x6" to 36"x36"	0" (0 mm)
Rectangular 6"x8" to 27"x48" (Max Height / Width ratio is 6:1. E.g, 6"x36")	0" (0 mm)

Clearance for Non-combustibles

0" clearance or as required for installation, access, inspection or per local code.

Framing Dimensions through Wall or Ceiling

Where the vent passes through the wall or ceiling, refer to section 4.

Joint Assembly

According to NFPA 96, all grease ducts are to be liquid tight. The following steps are to be used to ensure this requirement is met.

Use high temperature silicone sealant, Jeremias part number 101087A. WARNING: Do not substitute any type of water soluble sealants in the flange area.

To Install:

1. Inspect all liner flanges, and draw bands and straighten any mild deformations that may have occurred during shipping.
2. To ensure sealant adhesion, degrease and remove any dirt and debris from the liner flanges. Use an acetone based cleaner sprayed on a rag.
3. Apply a continuous bead of sealant (1/8" to 1/4") to one or both of the liner flanges to be joined.
4. Butt the flanged ends of the sections being joined, being careful not to smear off the sealant.
 - a. Install all supplied bolts/nuts finger tight. After all bolt/nuts are installed on a joint snug them up. After everything is snug finish tightening all bolts to an approx. torque of 4 ft-lb, per bolt manufactures recommended bolt torque.
 - b. Remove / wipe smooth any excess sealant on the inside of the assembled duct.
 - c. Allow sealant to cure 7 days before use. Sealant will not bond to flanges if moisture is introduced into system before sealant has cured.
5. With the provided insulation strip, wrap the assembled joint (3) times completely with a 2" overlap at the end of the last wrap. Wrap the joint tight enough for the insulation to fit snug in the space between the liner & shell. (This method applies wherever a joint requires to be wrapped prior to installing a draw band or cover.)
6. Complete the grease duct enclosure by placing the draw band around and overlapping the shell flanges of the assembled components. With the provided fasteners and appropriate tools draw up the band accordingly. It is recommended that sealant (provided by others) be applied to the draw band edges to prevent moisture from entering between the duct walls on all sections exposed to the atmosphere. As necessary, self tapping screws can also be used to help seal the draw band to the outer shell. (provided by others). Recommended to have a minimum of two screws, per band, in the vertical run.

Model DWGD-RZ	
Duct Size (Area)	# of Joints per Tube
6"x6" (36 in ²)	20
6"x12" (72 in ²)	13
6"x18" (108 in ²)	10
6"x24" (144 in ²)	8
6"X36" (216 in ²)	6
12"x24" (288 in ²)	5
12"x36" (432 in ²)	5
18"x36" (648 in ²)	4
24"x36" (864 in ²)	4
32"x34" (1088 in ²)	3
36"x36" (1296 in ²)	3

Table 1-6. Sealant Usage Chart

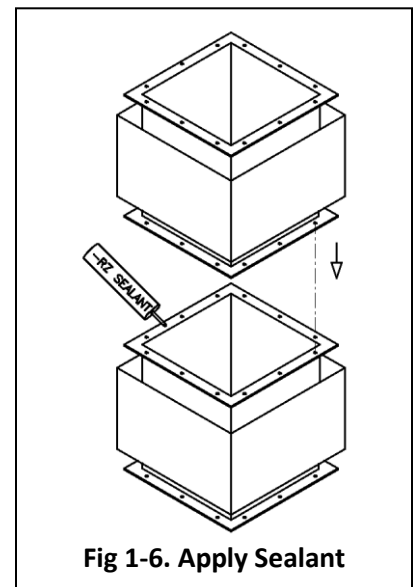

FLANGE / DRAW BAND FASTENERS

The fasteners provided with the flange are standard 1/4"-20 hex bolts and nuts. Draw band fasteners are 1/4" – 20 philips pan head screws with square nuts. Fittings come standard with draw band/cover, the fasteners provided for the flange will be plated steel. The provided fasteners for draw band/cover will be plated steel (where the shell is aluminized steel) or stainless steel (where the shell is stainless steel).

INSULATION - STRIP WIDTHS & FIRE STOP PACKING

Where the finished duct assembly uses a draw band (part DWGD-RZ**DRW*) a 4" wide roll of strip insulation is provided. Draw bands are typically used wherever standard fittings are assembled in series (most fittings are provided with a draw band and roll of insulation strips).

Where the duct penetrates through a wall or floor: a Fire Stop Penetration is to be used, the insulation for packing the opening is provided in 48" wide strips (the factory may provide 24" wide strips, or a package/container of insulation marked as "Fire Stop Packing Material" or "Fire Stop Insulation" as an alternate).

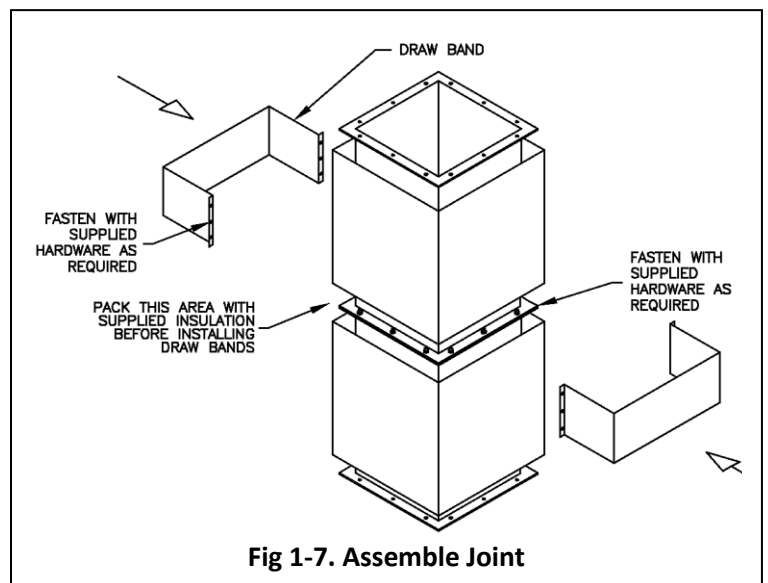

SECTION 2 – SUPPORT & GUIDING

NOTES: The structural engineer for the project should select support member channels, beams, rods, wires/cables, etc. and joining methods in accordance with Good Engineering Practices to suite each specific application. Rods, wires/cables should only be used for hangers, NOT supports. Jeremias accepts no responsibility for the design and/or modification of buildings or structures to accept the given load. All support framing, anchoring methods, etc. are by others.

Duct Weight

The approximate installed weight of DWGD-RZ duct systems can be found using Table 2-1. This table does not include accessories such as supports and guides, fittings nor shipping packaging or palletizing weight (See Table 2-1).

Vertical Support Spacing and Limits

DWGD-RZ Duct vent must be supported properly. Several support options are available. Refer to Table 2-2 for maximum support height capabilities. For all support options, ensure non-combustible hanger straps (or similar) are secured into joists or other solid structures. Ensure all minimum clearances to combustibles are maintained. Never drill or screw through the duct system. Additional support must always be located at an elbow or offset to prevent unacceptable stress on that fitting.

Model DWGD-RZ	
Duct Size (Area)	Lbs. per foot
6"x6" (36 in ²)	18
6"x12" (72 in ²)	24
6"x18" (108 in ²)	29
6"x24" (144 in ²)	35
6"X36" (216in ²)	41
12"x24" (288in ²)	47
12"x36" (432 in ²)	52
18"x36" (648 in ²)	58
24"x36" (864 in ²)	64
32"x34" (1088 in ²)	71
36"x36" (1296 in ²)	75

Table 2-1. Duct Weight

Table 2-2 – Maximum Support Height

Size (Area)	Maximum Support Height					
	Plate Support Assembly (PLS)	Flange Support Assembly (FSA)	Horizontal Angle Support or Unistrut Supports	Horizontal Hanger Bands (BHB)	Wall Brackets (WBR) 4" to 32"	Wall Brackets (WBR) 34" to 48"
Max Load (LBS)	2,400 Lbs.	3,400 Lbs.	500 Lbs.	420 Lbs.	1,300 Lbs.	900 Lbs.
Max Height (Ft.)						
6"x6" (36 in ²)	133.3	188.9	27.8	23.3	72.2	50.0
6"x12" (72 in ²)	100.0	141.7	20.8	17.5	54.2	37.5
6"x18" (108 in ²)	82.8	117.2	17.2	14.5	44.8	31.0
6"x24" (144 in ²)	68.6	97.1	14.3	12.0	37.1	25.7
6"X36" (216in ²)	58.5	82.9	12.2	10.2	31.7	22.0
12"x24" (288in ²)	51.1	72.3	10.6	8.9	27.7	19.1
12"x36" (432 in ²)	46.2	65.4	9.6	8.1	25.0	17.3
18"x36" (648 in ²)	41.4	58.6	8.6	7.2	22.4	15.5
24"x36" (864 in ²)	37.5	53.1	7.8	6.6	20.3	14.1
32"x34" (1088 in ²)	33.8	47.9	7.0	5.9	18.3	12.7
36"x36" (1296 in ²)	32.0	45.3	6.7	5.6	17.3	12.0

Lateral Guide Spacing

DWGD-RZ systems require guides to maintain proper alignment of the system and lateral support for wind loads. Refer to Table 2-3 & Fig. 2-1 (Dim B) for Lateral Guide Spacing.

Horizontal Support Spacing

Horizontal installations require guides to maintain proper alignment of the system and lateral support for wind loads. Horizontal supports are used in conjunction with rods or other field fabricated support members attached to the building or structure. Position the support away from draw bands & covers. Please note max. spacing of 12 foot making sure to stay within the weight limitation. Refer to Table 2-3 and Fig 2-2.

Table 2-3 – Maximum Lateral / Horizontal Spacing Between Supports

Size	Maximum Lateral Guide Spacing	Maximum Horizontal Support Spacing
All Sizes	30'	12'

Full Angle Support – (FAS)

Full angle supports, in conjunction with field fabricated support members from the FAS attached to the building or structure, are intended to laterally brace the vertical assembled duct lengths from wind loads and to also maintain alignment as the duct expands and contracts. The FAS is comprised of (2) halves and when bolted together is a slight clearance fit to the duct. Position the FAS away from draw bands & covers as to allow for the unrestricted expansion and contraction of the duct system. FAS's cannot be installed over draw bands. See Fig 2-1 & 2-2.

Guy Attachment Plate – (GAP)

Guy attachment plate, in conjunction with wires, tensioners, anchors, and other miscellaneous hardware from the GAP attached to the building structure, are intended to laterally brace the vertical assembled duct lengths from wind loads and to also maintain alignment as the duct expands and contracts. See Fig 2-3.

To Install:

1. Connect duct sections per the standard Joint Assembly instructions in section 1.
2. Install the necessary wires, tensioners, anchors & miscellaneous hardware (by others) to the plate of the GAP. A minimum of (4) wires/cables equally spaced is recommended.

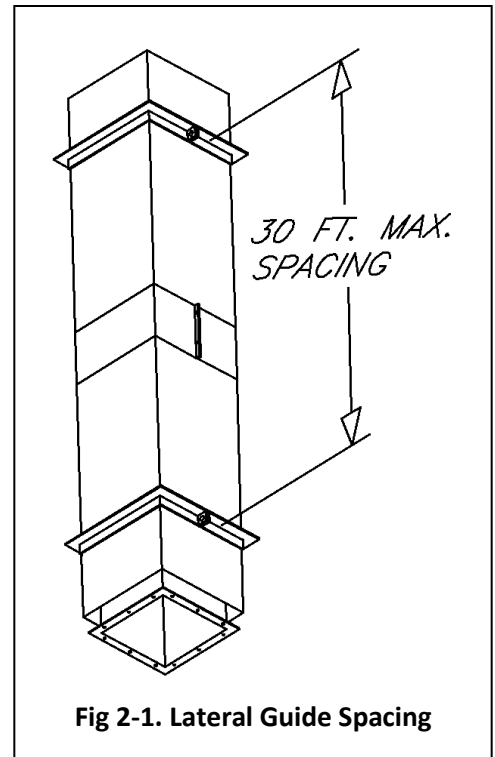

Fig 2-1. Lateral Guide Spacing

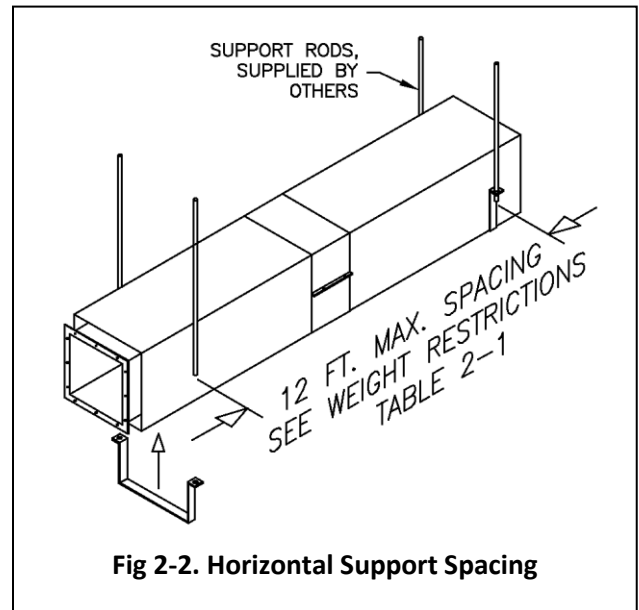

Fig 2-2. Horizontal Support Spacing

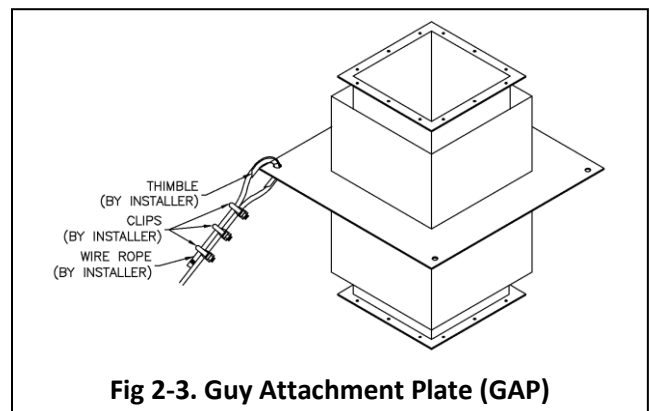

Fig 2-3. Guy Attachment Plate (GAP)

Plate Support Assembly – (PLS)

Plate support assemblies are used for vertical & horizontal (breaching anchor) structural support applications. The PLS is to be used with structural support members, which are designed by the building structural engineer. Refer to table 2-1 & 2-2 for structural support limitations.

To Install:

1. Refer to Table 2-1 & 2-2 for load limitations.
2. Position the plate support between the flanges. See Fig 2-5.
3. Secure the joint per the standard Joint Assembly Instructions, sandwiching the plate support between the duct flanges.
4. Fasten / secure Plate Support to Structural Members. Do not install to combustible material. Ensure all four sides of the plate are supported. Design support member and fasteners in accordance with good engineering practices to suit each specific application. Jeremias assumes no responsibility for the design and/or modification of buildings or structures to accept the given loads. See Fig 2-6 & 2-7.

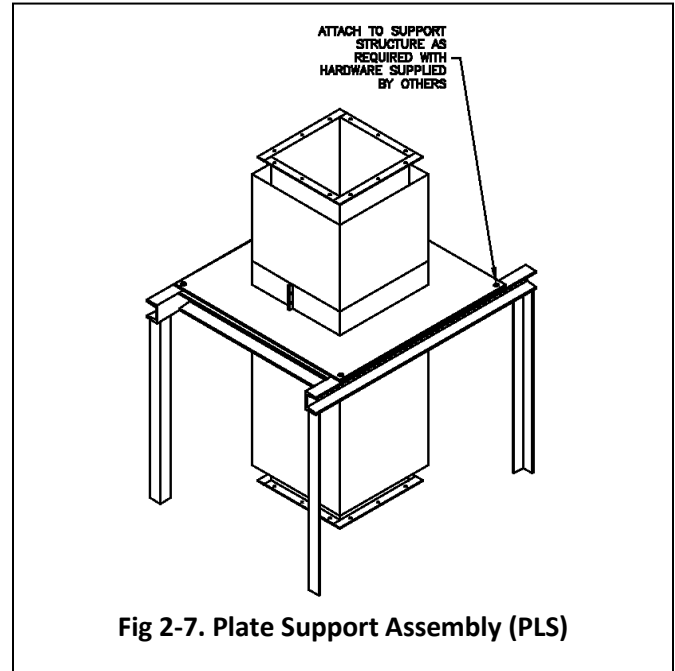
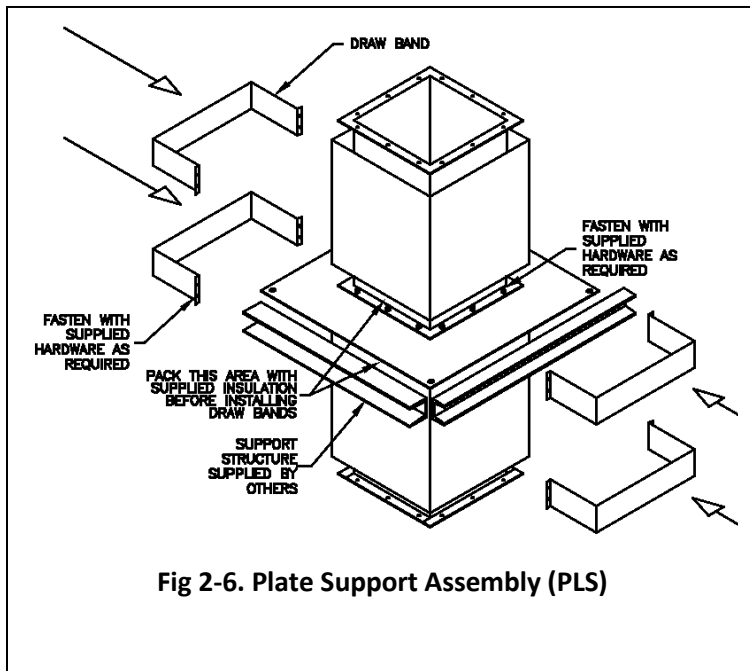
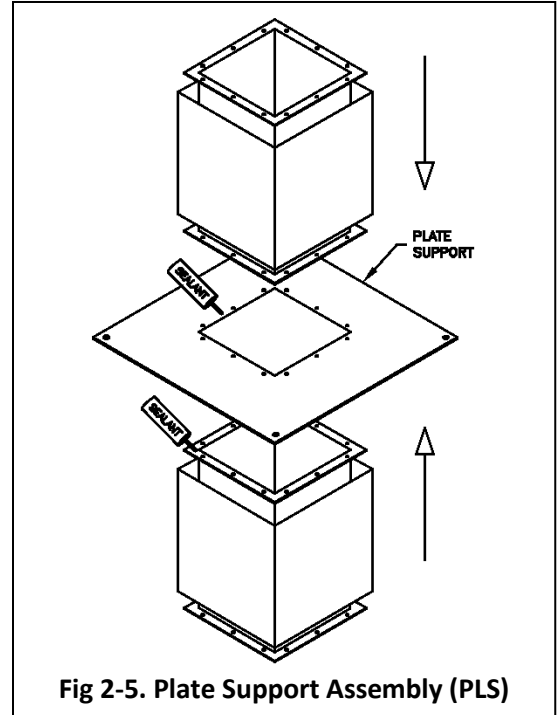
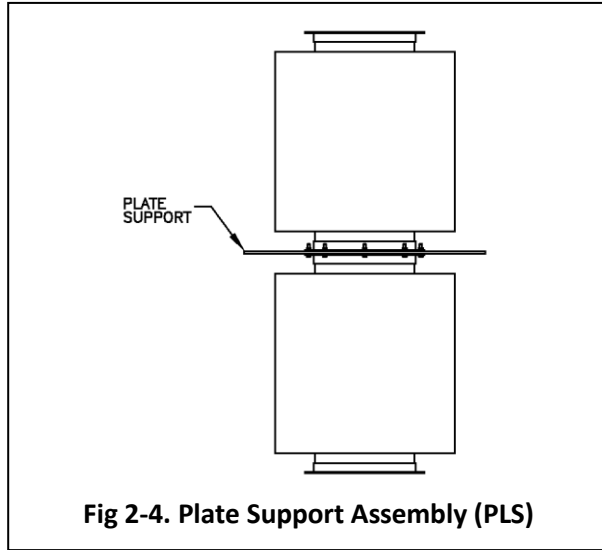

Flange Support Assembly – (FSA)

A Flange Support Assembly is a prefabricated duct section with a plate support installed at the factory for structural support applications. The FSA is to be used with structural support members, which are designed by the building structural engineer.

To Install:

1. Refer to Table 2-1 & 2-2 for load limitations.
2. Fasten / secure Plate Support to Structural Members. Do not install to combustible material. Ensure all four sides of the plate are supported. Design support member and fasteners in accordance with good engineering practices to suit each specific application. Jeremias assumes no responsibility for the design and/or modification of buildings or structures to accept the given loads. See Fig 2-8.
3. Refer to Joint Assembly section to connect adjacent duct segments to the FSA.

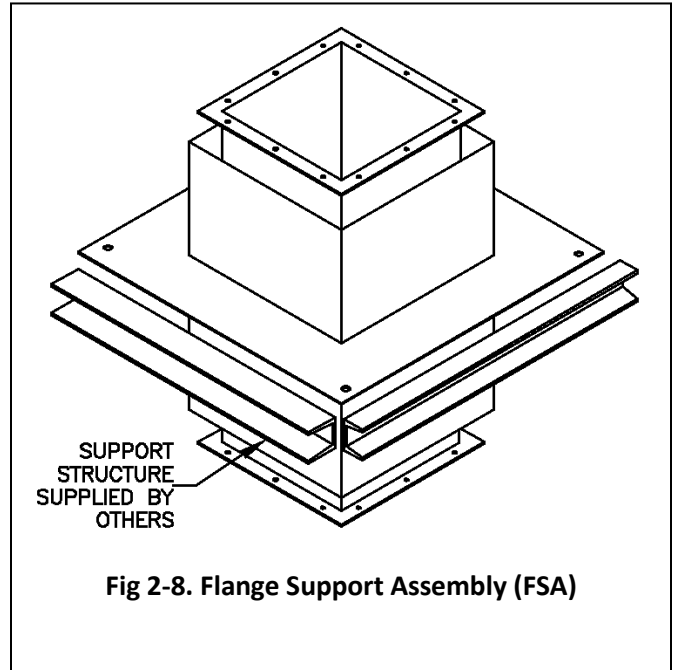

Wall Brackets – (WBR)

Wall brackets are used in conjunction with our vertical and horizontal structural and lateral supports. The WBR, in conjunction with anchor bolts or in some instances additional field fabricated support members from the wall brackets to the building or structure, is intended to provide a rigid (static) support location. This rigid support location is intended to withstand the weight of duct components, forces from thermal expansion & exhaust velocities, etc. The WBR is comprised of (2) wall brackets, (left and right).

To Install:

1. Refer to Table 2-1 & 2-2 for load limitations.
2. Anchor the wall brackets to the wall or additional field fabricated support members accordingly. Design support member and fasteners in accordance with good engineering practices to suit each specific application. Consult structural engineer regarding design and/or modification of buildings or structures to accept the given loads. Do not anchor to combustible material. See Fig 2-9 to 2-11.

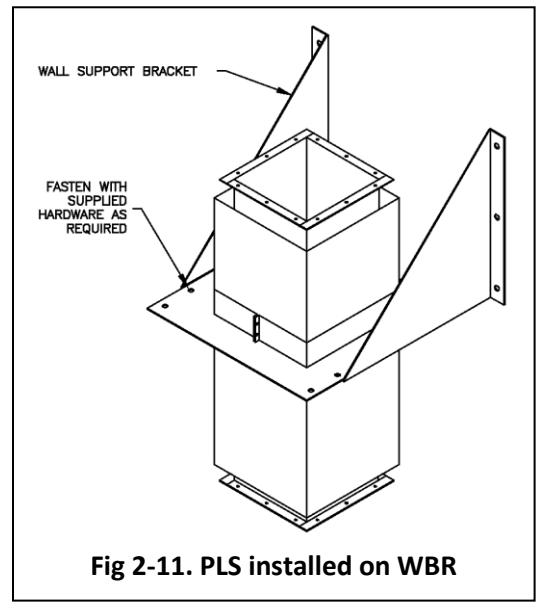
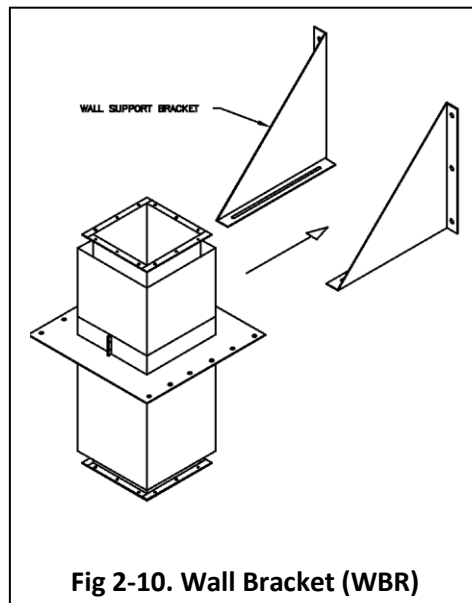
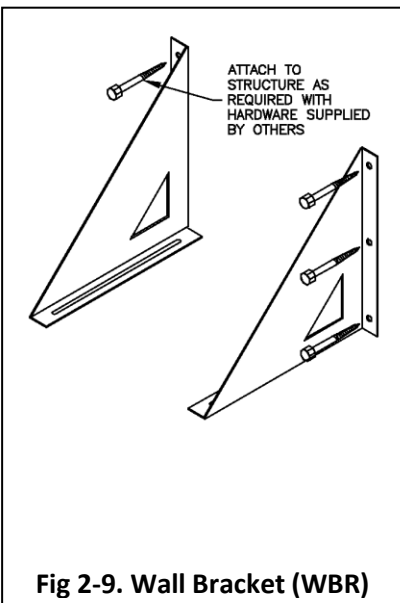

SECTION 3 – DUCT SECTIONS & FITTINGS

Duct Sections

A wide range of prefabricated adapters, fittings, elbows, wye's, tee's, transitions, increasers, terminations, etc are available. Sections may also be equipped (must be factory installed) with nipples or couplings to accommodate test probes, fire suppression nozzles, sprinkler heads, drainage, etc. Refer to the DWGD-RZ catalog for additional information on part number designations and the wide range of parts and fittings we offer to complete a system from start to finish. Additionally, where required, custom lengths may be ordered from Jeremias Inc.

Straight Sections (STR)

Model DWGD-RZ is available in a variety of fixed duct lengths (e.g., 18", 30" & 42"). Refer to the catalog for available sizes. Additionally, where required, custom lengths may be ordered from Jeremias Inc. Refer to the corresponding Joint Assembly section for installation instructions. See Fig 3-1.

Elbow (E)

Elbows are used to provide changes in direction. They are available in a variety of standard angles (1.5°, 3°, 15°, 30°, 45°, 70°, 87°, & 90°). Refer to the catalog for available sizes. Additionally, where available, custom elbows may be ordered from Jeremias Inc. Elbows are installed similar to standard duct. Refer to the corresponding Joint Assembly section for installation instructions. See Fig 3-2.

Tee (90T)

Used as a manifold entry Tee, offset with one of the access cap options, or cleanout option. Branch can be same or any size smaller than the body. See Fig 3-3.

Wye Tee (WYE)

Used for two-way entries where a tee cap or access cannot be used due to the application or as a 90° that can have an access cap at the middle.

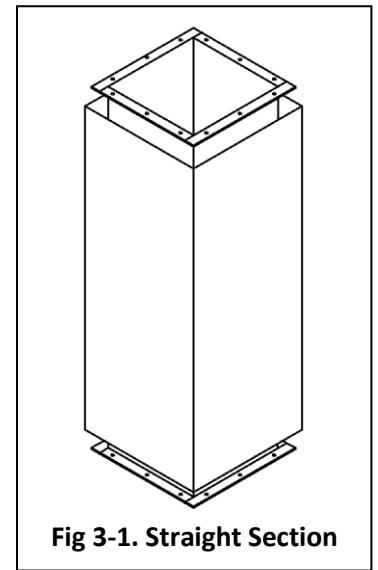

Fig 3-1. Straight Section

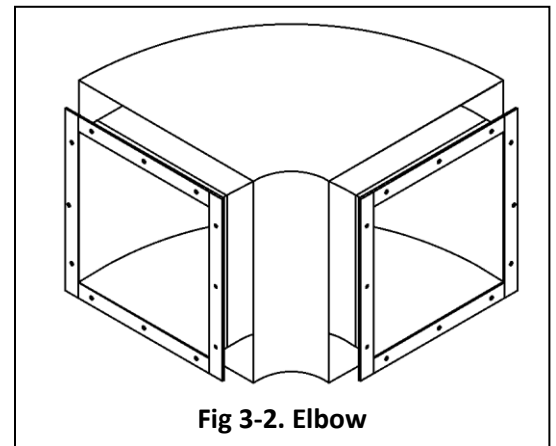

Fig 3-2. Elbow

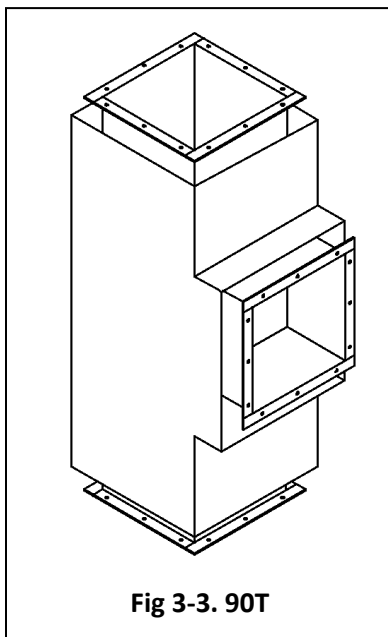

Fig 3-3. 90T

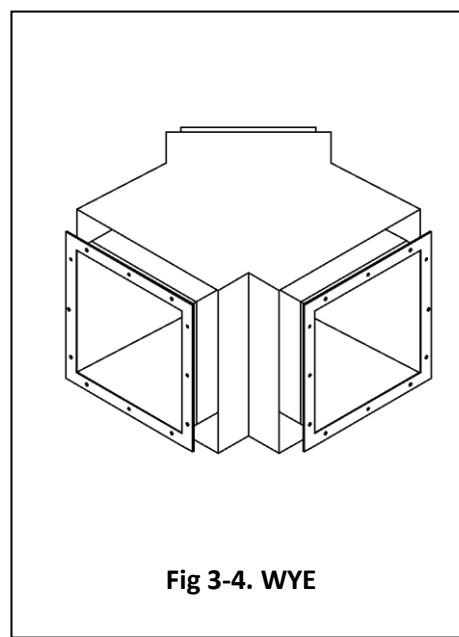

Fig 3-4. WYE

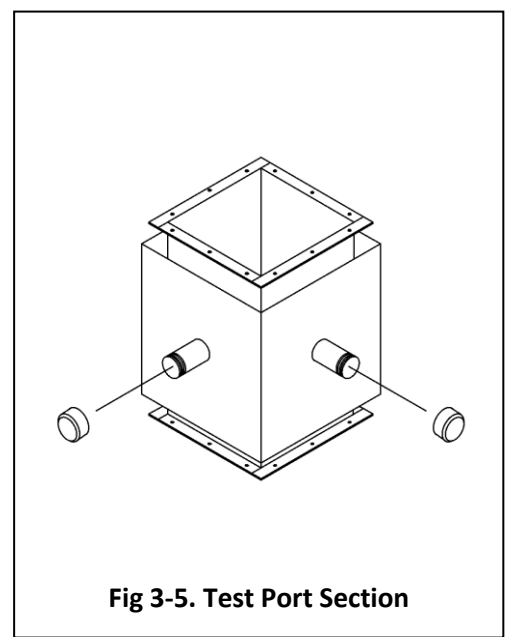
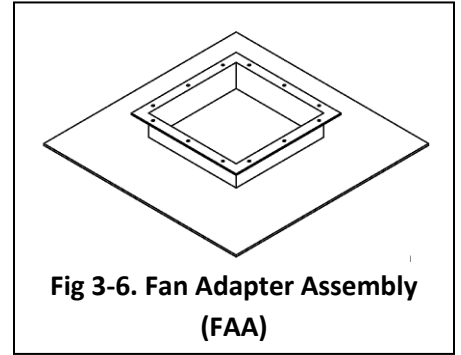

Fig 3-5. Test Port Section

Fan/Hood Adapter Assembly – (FAA)

The fan adapter assembly is intended to be used with a “traditional” roof curb (provided by others) and connection to a hood or an exhaust fan. The FAA is comprised of a fan adapter plate (specify plate size at time of purchase) with a factory installed starter section that assembles to a standard fitting. Field connect the plate to the hood, curb or fan by (drilling / fasteners & sealant by others as required). Refer to the hood, fan unit or the roof curb manufacturer’s installation requirements. (See Fig 3-6).



ACCESS PANEL SECTION – (APS)

This part is intended to be used for clean out access. When the access panel section is installed in a horizontal position, it must be orientated in accordance with applicable codes. Please refer to the DWGD-RZ catalog for additional information and part number designation. See Fig 3-7.

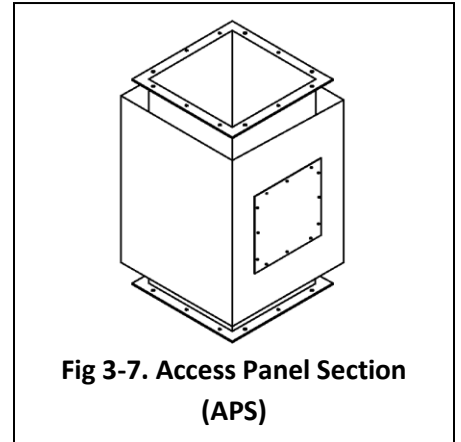

Open Top Closure – (OTC)

The open top closure covers the space between the liner and shell. First, position the OTC around the liner. Next, butt the OTC up against the flange of the liner and using the provided fasteners draw up the OTC. Last, apply a bead of sealant at the seam formed between OTC and the liner to form a weather tight seal. See Fig 3-8.

Rain Cap – (RCS)

Rain caps connect to the liner flange per the joint assembly instructions. The space between the liner and shell is then covered using a rain skirt. The rain skirt is installed by positioning the rain skirt around the liner just below the previously installed flange. Next, using the provided fasteners draw up the rain skirt (the rain skirt should be overlapping and in contact with the top of the shell). Last, apply a bead of sealant at the seam formed between rain skirt and the liner to form a weather tight seal. See Fig 3-9.

Increasesers and Reducers

Reduction fittings are typically used in manifold applications when needed. There are many options for increasers and reducers.

Single-to-Double-Wall / Double-to-Single-Wall Adapters (D2S & S2D)

These adapters allow a smooth transition to and from double wall and single wall. They may be installed vertically or horizontally. Adapters are made to order for project requirements.

Transition to Round Start & End (TRS & TRE)

Used to connect to and from rectangular or square outlets on hood, fans, or auxiliary equipment. Transitions are custom made to order for project requirements. The rectangular or square base can be made in accordance with NFPA-96 no-weld hood connection or may be field welded by the installing contractor.

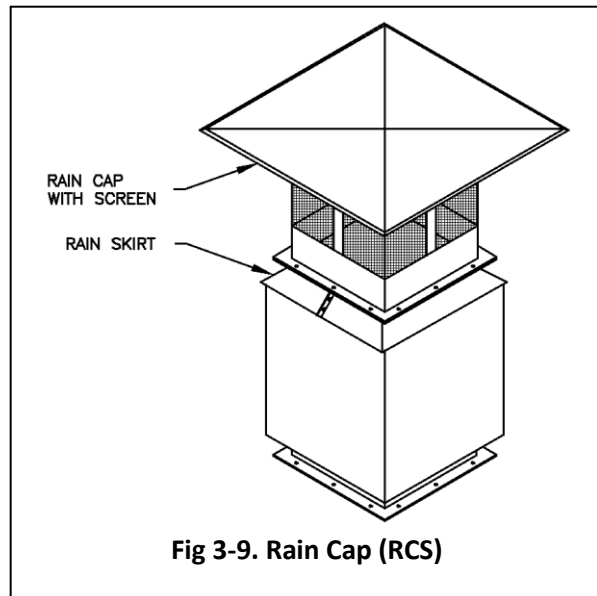
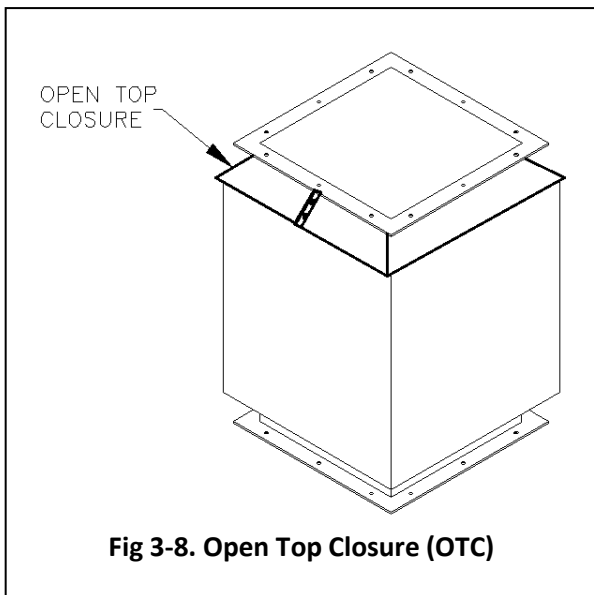

Floor Penetration Assembly – (FPA)

This penetration assembly must be used when the duct passes through a fire-resistant floor (refer to codes / authorities for specific requirements on fire resistant floors). Refer to Listings & Certifications in Section 1 for rating of floor penetration. The duct section passing through the floor must be isolated from the effects of thermal expansion and proper support using one of our structural supports, refer to Supports in Section 2 for structural support info. The FPA includes (1) top plate assembly, and one bottom plate assembly, insulation sheet(s) and insulation strips.

To Install:

1. Cut the rough floor opening. The rough opening (square or rectangular opening allowed) can vary between duct O.D. +2" and duct O.D. +8" Assemble the duct through the rough opening such that there is a 1" minimum and 4" maximum clearance between any single edge of the opening and the O.D. of the duct. Floor opening shall not exceed 40" x 61".
2. Position the bottom plates around the duct and against the underside of the floor. With fasteners (by others) draw up the plate. Anchor the plate to the floor with concrete screws 1/4" x 1-3/4" min. and then to the duct with No. 6 x 3/4" long sheet metal screws, (by others) at all factory hole locations. Use fire caulk (3M fire barrier or equivalent, by others) to fill any gaps between the plate and the duct or the plate and the floor.
3. With the provided insulation pack the cavity around the duct and the floor, being careful to stagger any seams or joints. Continue pressing insulation into the cavity until the insulated area is very firm & densely packed to approximately 40% compression leaving a 3/8" recess from top of the floor to the packing material.
4. Fill the 3/8" void with one of the sealants listed below (by others). Screed the area flush with the top of the floor.
 - a. Approved Sealants: 3M: 1000-NS, 1000-SL, 2000+ or CP 25 WB+. Tremco: TREMstop Fyre-Sil GG, Fyre-Sil SL. STI: SpecSeal Series SSS. Hilti: FS-ONE
5. After sealant has skimmed over, install the top plates similar to STEP 2
6. Next, install the provided insulation similar to STEP 3, without the 3/8" recess.

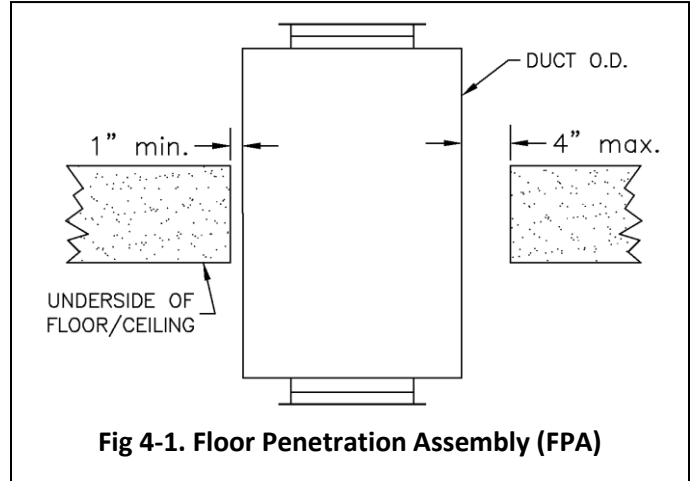

Fig 4-1. Floor Penetration Assembly (FPA)

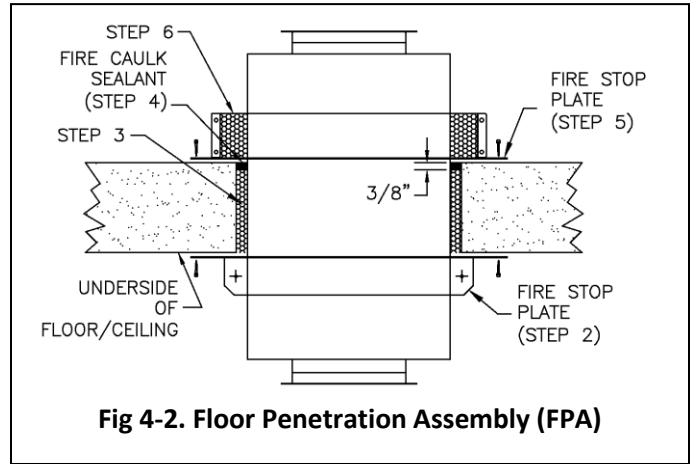

Fig 4-2. Floor Penetration Assembly (FPA)

Wall Penetration Assembly – (WPA)

This penetration assembly must be used when the duct passes through an interior fire resistant wall (refer to codes / authorities for specific requirements on fire resistant walls). Refer to Listings & Certifications in Section 1 for rating of wall penetration. The duct section passing through the wall must be isolated from the effects of thermal expansion and proper support using one of our structural supports refer to Supports in Section 2 for structural support info. If the duct is passing through a gypsum board wall of appropriate construction, the rough opening between the gypsum boards must be completely closed off and reinforced with metal studs. A CMU (hollow block) wall may also be penetrated. The rough opening should be done in a fashion such that the precast edges of the blocks form a continuous solid edge. Please note: The WPA includes (2) Wall penetration plate assemblies insulation sheet(s), and insulation strips.

To Install:

1. Cut the rough wall opening. The rough opening (square or rectangular opening allowed) can vary between duct O.D. +2" and duct O.D. +8". Assemble the duct through the rough opening such that there is a 1" minimum and 4" maximum clearance between any single edge of the opening and the O.D. of the duct. Wall opening shall not exceed 40" x 61".
2. With the provided insulation pack the cavity around the duct and the wall, being careful to stagger any seams or joints. Continue pressing insulation into the cavity until the insulated area is very firm & densely packed approximately 40% compression leaving a 5/8" recess from wall to the packing material on both sides of the wall.
3. Fill the 5/8" void with one of the sealants listed below (by others). Scream the area flush with the edge of the wall.
 - a. Approved Sealants: 3M: 1000-NS, 2000+ or CP 25 WB+.
Tremco: TREMstop Fyre-Sil GG. STI: SpecSeal Series SSS.
Hilti: FS-ONE
4. Position the halves of the plate around the duct and against both sides of the wall. With fasteners (by others) draw up the plate. Anchor the plate to the wall with concrete screws 1/4" x 1-3/4" or self-drilling screws 1/4" x 2" min. and then to the duct with No. 6 x 3/4" long sheet metal screws (by others) at all factory hole locations. Use fire caulk (3M fire barrier or equivalent, by others) to fill any gaps between the plate and the duct or the plate and the floor.
5. Install the provided insulation similar to STEP 3, without the 5/8" recess.

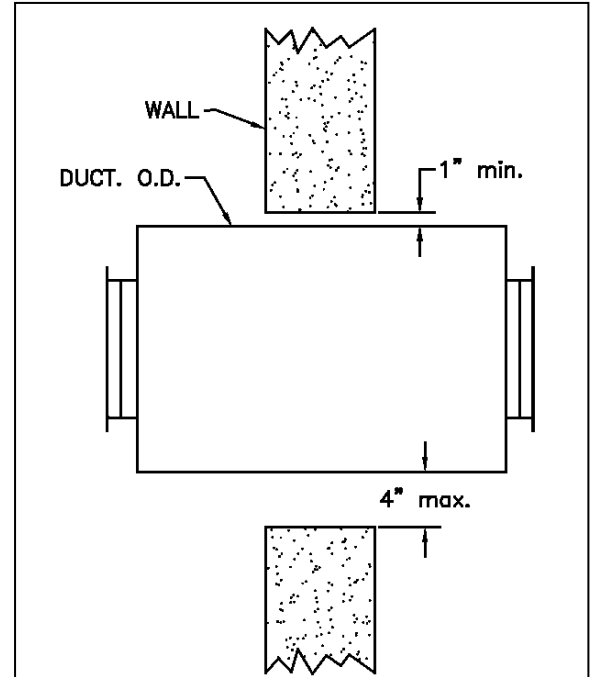

Fig 4-3. Wall Penetration Assembly (WPA)

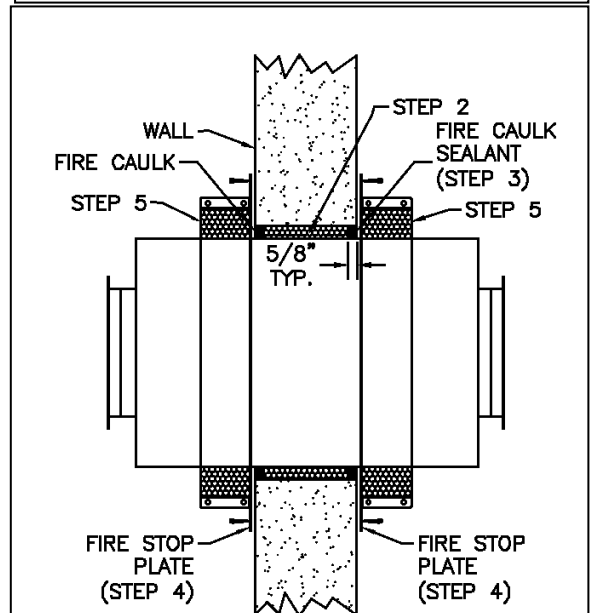

Fig 4-4. Wall Penetration Assembly (FPA)

Floors/Ceilings & Walls - Fire Rating Not Required

Finishing Plate – (FPL)

The finishing plate can be used when the duct passes through a floor/ceiling or wall where a fire rating is not required. The minimum rough opening (square or round opening allowed) must be enough to allow the duct to pass through, approximately duct O.D. +2". The maximum rough opening is duct O.D. +8" (Max. opening size when duct is centered through the opening). The FPL includes (1) plate assembly. Please note two plate assemblies shown below in the picture.

To Install:

1. Cut the rough opening accordingly and assemble the duct through. Position the plate halves (allow slight clearance to the duct O.D. to accommodate any expansion as needed), Anchor the plates with appropriate fasteners (by others) at hole locations

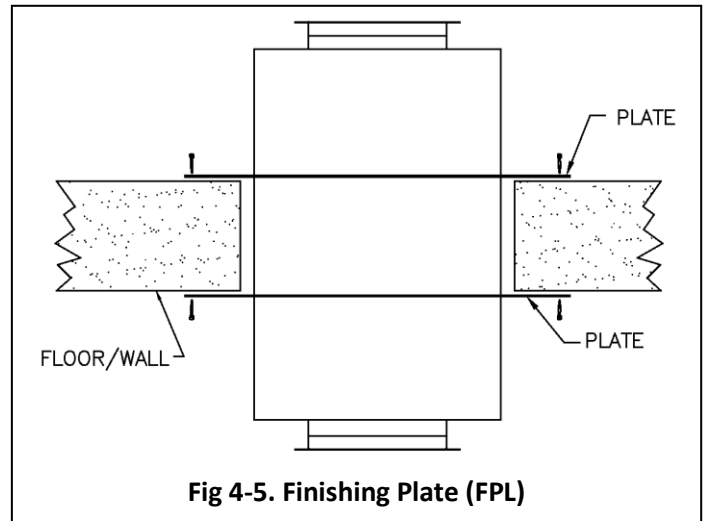

Fig 4-5. Finishing Plate (FPL)

Roof Penetration

Flashing & Counter Flashing – (FLS & CFL)

The flashing and counter flashing can be used when the duct passes through a roof or curb where a roof penetration thimble is not required. Pitched flashings are available please refer to the model DWGD-RZ brochure accordingly. The minimum rough opening (square or rectangular opening allowed) must be enough to allow the duct to pass through, approximately duct O.D. +2". The maximum recommended rough opening is duct O.D. +8" (reflects flat roof only and duct centered through opening).

To Install:

1. Cut the rough roof opening. Center the flashing around the opening and with appropriate fasteners attach it to the roof. Roofing materials to complete a weather tight seal should be installed over the square base of the flashing.
2. Assemble the duct through the flashing accordingly. Next, install the counter flashing by positioning it around the duct and against the screen at the top of the flashing. Then, with the provided fasteners draw up the counter flashing. Last, apply a bead of sealant at the seam of the counter flashing and duct. Note: Roofing materials must not fill the entire space between the roof and the bottom of the counter flashing.

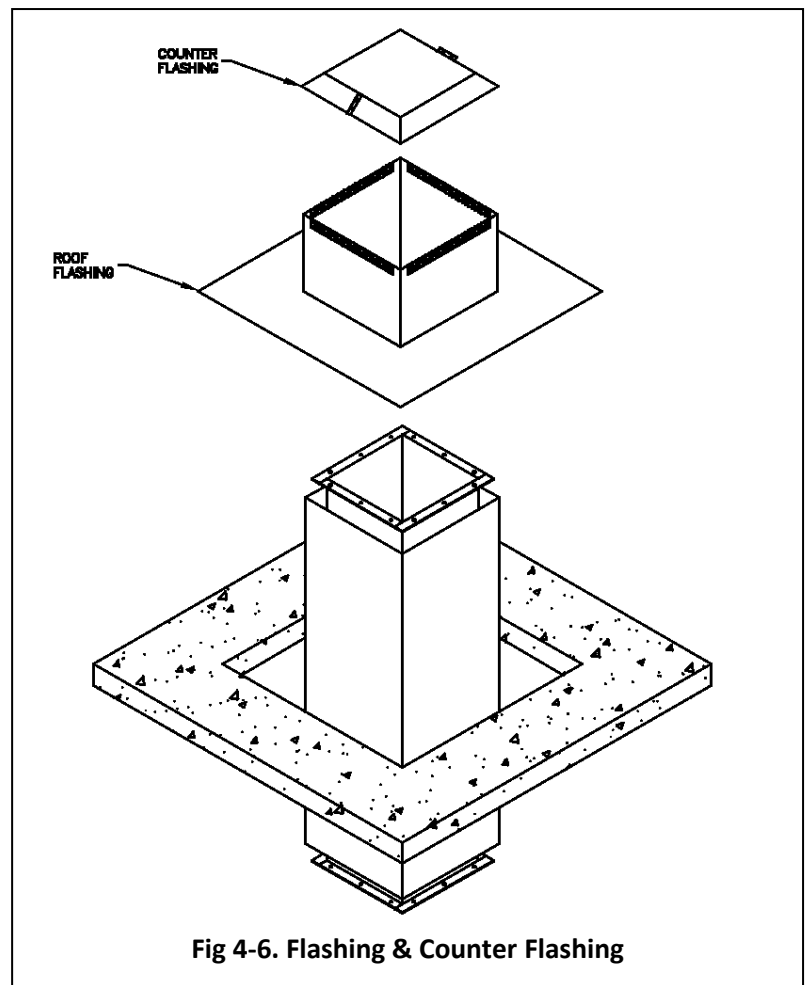

Fig 4-6. Flashing & Counter Flashing

Final Check

Before completing assembly, recheck all joints to ensure the locking band has been properly installed. Confirm all clearances and support spacing is correct.

Important Notice

The listing for this product is void if components other than the Listed Components are used. All warranties, stated or implied, are void if the vent or appliance is installed in a non-conforming manner. After installation, check all joints and supports to assure they are secure and functioning as intended and are properly sealed for containment of flue gases.

Maintenance

Jeremias recommends that the entire system be checked by a qualified inspector at least once a year after the system is placed in service. The installation must conform to the requirements of the appliance manufacturer's instructions, the National Fuel Gas Code and local codes and regulations.

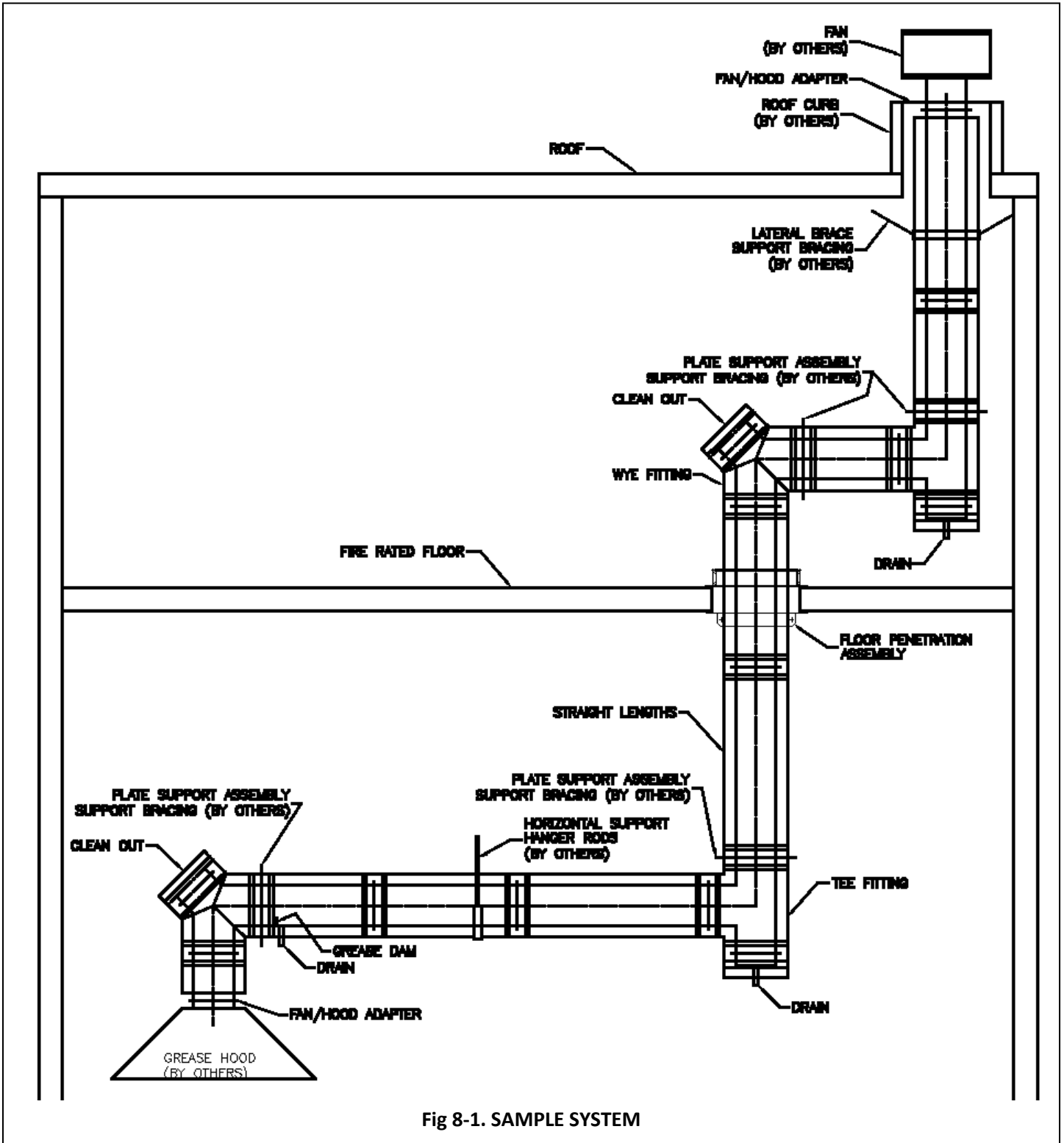

Fig 8-1. SAMPLE SYSTEM

PART 7 – Warranty

I. 1-Year Limited Warranty

Jeremias Inc. (“Jeremias”) provides a 1-year limited warranty (“1-Year Limited Warranty”) for its UL1978 & UL2221 grease ducts Model DWGD-RZ (collectively, the “Products”) for any defect in workmanship or materials under normal use from the date of shipment to the purchaser of Products (“Purchaser”), subject to the following conditions:

- Product sizing and specifications have been performed in accordance with generally accepted engineering practices.
- Correct installation and maintenance in full compliance with Jeremias’ installation and maintenance instructions as published at the time of installation.

II. Extended 10-Year Limited Warranty

Jeremias provides for an extended 10-year limited warranty (“10-Year Limited Warranty”) for any defect in workmanship or materials under normal use from the date of shipment to the Purchaser, subject to the satisfaction of the following conditions:

- Products must have been designed and sized by Jeremias’ personnel.
- Availability of a written inspection report from the time of installation, or timely thereafter, by a Jeremias inspector or an inspector authorized by Jeremias, that the Product assembly and installation conformed to all of Jeremias’ assembly and installation instructions.
- Products were at all times operated and maintained in full compliance with Jeremias’ operation and maintenance instructions as published at the time of installation or as later provided to Purchaser by Jeremias.

III. Exclusion of Limited Warranty

The 1-Year Limited Warranty and the 10-Year Limited Warranty (collectively the “Limited Warranty”) shall not cover (i) damages to: wear parts, e.g. seals; demonstration units; paintwork; moving parts, including but not limited to compensators, flue gas dampers, draught regulators, chimney, doors; flexible piping; insulation; consumables, such as granulates; minor Product deviations which do not effect functionality; or (ii) damages caused by: contamination of ambient air or combustion air by chlorinated hydrocarbons or other vapors which may cause excessively severe acid condensate to form within the Products; merchandise provided by other manufacturers; installation, transport or commissioning; Purchaser, an installer or other third parties; normal wear and tear; any party other than Jeremias in a willful manner; force majeure, including, but not limited to flood, fire or frost; non-compliance with the assembly, installation, operation and maintenance instructions available at www.JeremiasInc.com; assembly, installation, maintenance or repair by unqualified personnel; improper commissioning; use of Products not in accordance with their intended purpose; exposure of Products to any metals of an inferior quality; contamination of the Products between unpacking and assembly; burning of wood other than unpainted, natural wood, which has been stored for at least 3 years and which moisture level does not exceed 20%; or burning of chipboard or domestic waste.

IV. Remedies

If a valid Limited Warranty claim arises, Jeremias shall, at its sole discretion, either repair the Product or deliver a properly functioning Product. This Limited Warranty is limited to repair or replacement of the Product plus shipping cost to the location of the defective Product. The Limited Warranty does not cover labor costs for removal or replacement of the defective Product, unless such labor shall be carried out by Jeremias itself in its sole discretion.

V. Filing of a Limited Warranty Claim

Limited Warranty claims may only be asserted during the term of the applicable Limited Warranty period. Any extension of the term of the Limited Warranties shall be excluded, regardless of the legal basis. If Purchaser believes that there is a justified Limited Warranty claim, Purchaser shall notify Jeremias to that effect in writing. Any claims stemming from or relating to a Limited Warranty shall be asserted in detail within eight weeks after the discovery of the defect (the time when the notification is received by Jeremias will be the basis for determining whether a claim has been reported within this deadline) or else shall be excluded and not be recognized by Purchaser. Such notification shall include a description of the defect, original proof of purchase, and a copy of the written inspection report as described in Section II above (if applicable).

VI. No Other Warranty

EXCEPT AS SET FORTH EXPRESSLY THEREIN, JEREMIAS MAKES NO WARRANTIES, EITHER EXPRESS OR IMPLIED, REGARDING THE PRODUCTS, INCLUDING, BUT NOT LIMITED TO, THE IMPLIED WARRANTIES OF MERCHANTABILITY AND FITNESS FOR A PARTICULAR PURPOSE.

VII. Damages Disclaimer and Limitation

IN NO EVENT SHALL JEREMIAS BE LIABLE TO ANY CLIENT OR ANY OTHER PERSON FOR ANY (A) INDIRECT, INCIDENTAL, CONSEQUENTIAL OR PUNITIVE DAMAGES, INCLUDING LOSS OF PROFIT OR GOODWILL OR (B) DIRECT DAMAGES TO BODY, HEALTH OR PROPERTY FOR ANY MATTER ARISING OUT OF OR RELATING TO THE PRODUCTS, WHETHER SUCH LIABILITY IS ASSERTED ON THE BASIS OF CONTRACT, TORT OR OTHERWISE EVEN IF JEREMIAS HAS BEEN ADVISED OF THE POSSIBILITY OF SUCH DAMAGES. IN NO EVENT SHALL JEREMIAS’ TOTAL AGGREGATE LIABILITY FOR DAMAGES EXCEED THE GREATER OF THE AMOUNT OF (A) TOTAL COMPENSATION PAID BY PURCHASER TO JEREMIAS FOR THE PRODUCTS, OR (B) PROCEEDS AVAILABLE FROM ANY INSURANCE POLICY IN EFFECT AND APPLICABLE TO THE EVENT GIVING RISE TO SUCH LIABILITY.

VIII. Notice

Any notice or other communication hereunder to Jeremias shall be sent postage prepaid, by certified mail, by courier such as United Parcel Service or e-mail, to the following: Jeremias Inc., 983 Industrial Park Drive, Marietta, GA 30062, E-mail: Info@JeremiasInc.com. Notices shall be effective upon receipt.

IX. Terms and Conditions of Sale

Purchaser’s Terms and Conditions of Sale as currently in effect shall govern these Limited Warranties, including without limitation the rights and responsibilities granted hereunder. Jeremias Warranty and Terms & Conditions apply. Visit: <https://jeremiasinc.com/downloads/terms-conditions/>

NOTES



Jeremias Inc.

983 Industrial Park Drive, Marietta, GA 30062